

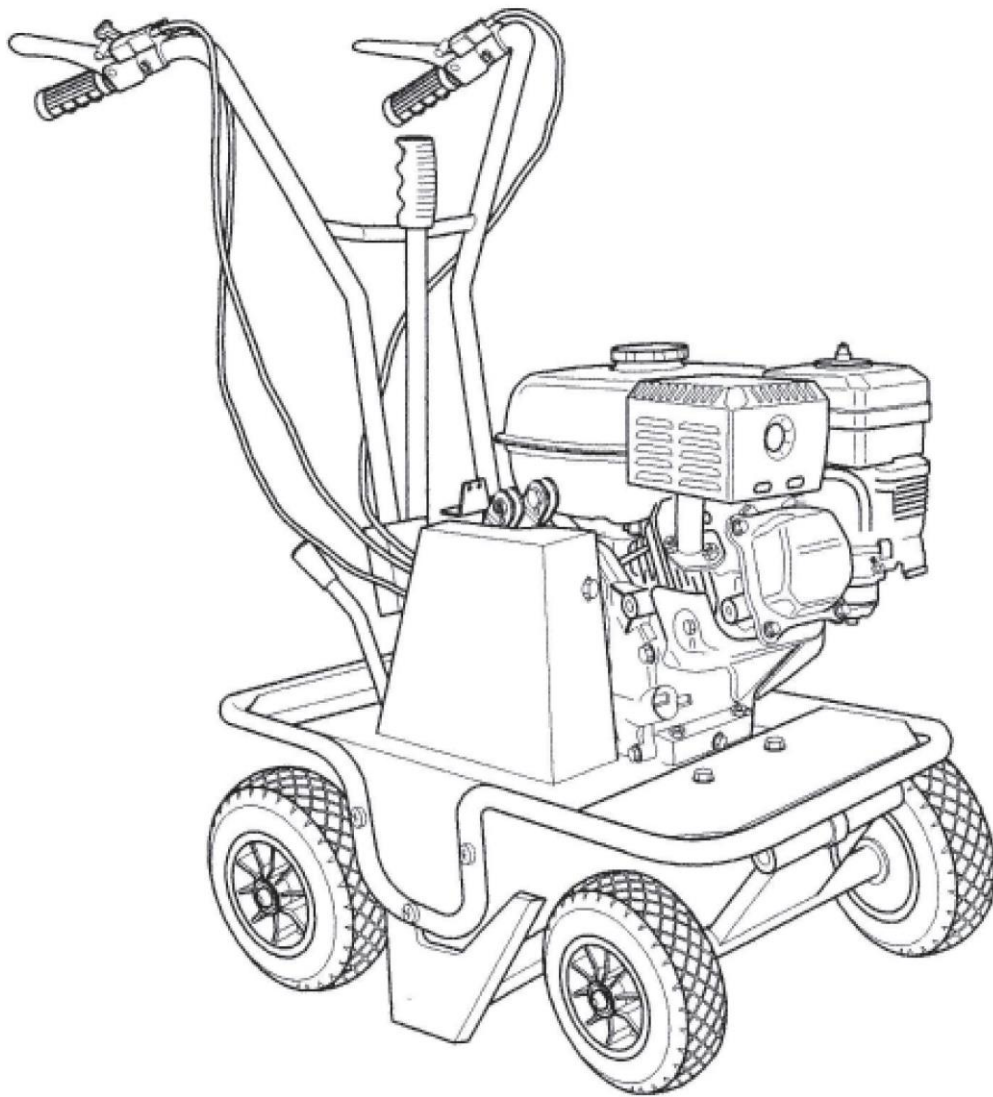

IB 300 - IB 390

TURF CUTTER



OPERATING AND SAFETY INSTRUCTIONS

- CONTENTS OF THE TURF CUTTER MANUAL -

1.	USE OF THE MANUAL.....	page 4
2.	NOTICES ON THE MACHINE.....	page 5
3.	TECHNICAL DATA.....	page 7
4.	LIFTING AND TRANSPORTATION.....	page 8
5.	MAIN PARTS OF THE MACHINE.....	page 9
6.	CONTROLS AND ADJUSTMENTS.....	page 10
7.	ASSEMBLY INSTRUCTIONS FOR THE HANDLEBARS AND END PART OF THE CUTTING HEIGHT ADJUSTMENT LEVER.	page 11
8.	SAFETY INFORMATION	
	A) GENERAL INSTRUCTIONS.	page 12
	B) TRAINING	page 12
	C) PREPARATION.	page 12
	D) WORKING USE.....	page 13
	E) SERVICE BRAKE CHECKING	page 14
9.	TRANSPORTATION OF THE MACHINE.....	page 14
10.	DESCRIPTION OF THE SAFETY SYSTEMS AND GUARDS.....	page 14
11.	OPERATIONS TO BE CARRIED OUT BEFORE SWITCHING ON.	page 15
12.	STARTING AND DRIVING THE TURF CUTTER.....	page 16
13.	CUTTING TIPS.....	page 17
14.	CHECKS	
	A) TYRE PRESSURE.....	page 18
	B) CABLE CONTROL ADJUSTMENT.....	page 18
	C) BELT REPLACEMENT AND ADJUSTMENT	page 19
	D) SERVICE BRAKE CHECKING.....	page 22
	E) CHECKING AND REPLACING THE BLADE.....	page 22
15.	MAINTENANCE AND STORAGE.....	page 23
16.	CLEANING THE MACHINE.....	page 24
17.	SEASONAL LONG-TERM STORAGE PERIODS.....	page 25
18.	DECOMMISSIONING AND SCRAPPING	page 25
19.	TECHNICAL ASSISTANCE.....	page 25
20.	WARRANTY	page 26
21.	CE MARKING	page 27
22.	TROUBLESHOOTING	page 28

Enclosure 1. NOTES

Enclosure 2. DECLARATION OF CONFORMITY

OPERATING AND SAFETY INSTRUCTIONS

TURF CUTTER MOD. IB300 - IB390

FOREWORD

This machine may only be utilized for the purpose for which it was designed, i.e. agricultural use, for the cutting of shoots, grass and brushwood.

Any other use other than that stated, not covered or deducible from this Manual and the enclosed Engine Manual is "PROHIBITED".

Failure to comply with instructions in this Manual and in the Engine Manual releases the manufacturer from all liability, in particular for any damage resulting from improper or incorrect use, through negligence, superficial interpretation or flagrant disregard for the safety requirements herein.

Get your dealer to explain how to use the machine in optimum safety conditions.

Always perform the checks as prescribed herein before each work session with the machine. Should any information given in the following pages be unclear or not straightforward please contact the manufacturer directly.

1. USE OF THE MANUAL

This Manual consists of numbered pages and enclosures featured in the list of contents. Before operating the machine the user must read the instructions in the Operator's Manual carefully as well as those of the Engine Manual enclosed.

Use of the turf cutter by more than one operator (individually), means that they must have carefully read the Operator's Manual and the Engine Manual **before using it**.

The aforementioned manuals form an integral part of the machine and must therefore be kept intact and in good condition, in a known, easily accessible place for the entire working life of the machine, even if the turf cutter is passed on to another owner. The purpose of these manuals is to provide the information necessary for the safe and competent use of the product. In the instance of wear or purely for a greater technical working knowledge, the manufacturer may be contacted directly. The Notes Section at the end of the Turf cutter Manual is for the addition of any complementary notes.

In this Manual all safety information appears in special boxes headed "WARNING".

WARNING

This heading is used to draw the user's attention to hazardous areas or moving parts of the machine. It is also used in instances where failure to comply with the instructions given may result in injury to persons and animals or damage to property.

2. NOTICES ON THE MACHINE

The symbols affixed to the machine serve to warn of danger during its use and maintenance. It is vitally important to understand the meaning of the danger notices and all messages should be kept in legible condition. In the instance of wear these notices should be replaced and use of the machine suspended while without such notices.

The operator is advised to observe the warnings given on the affixed notices.

The symbols affixed to the machine serving to warn of danger during its use and maintenance are as follows:

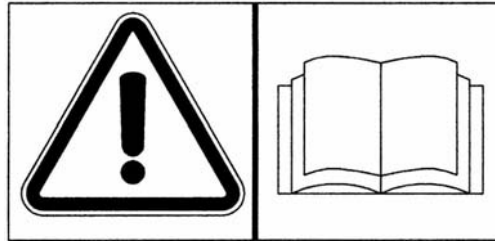

THE USER MUST READ THE INSTRUCTION MANUAL PROVIDED

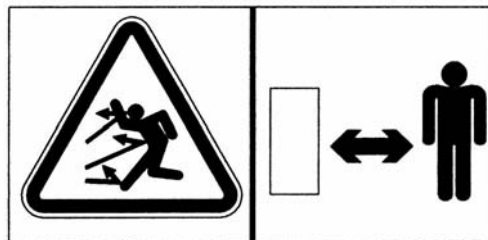

DANGER OF FOREIGN OBJECTS BEING THROWN OUTWARDS. KEEP A SAFE DISTANCE



ALWAYS DISCONNECT THE CABLE FROM THE ENGINE SPARK PLUG

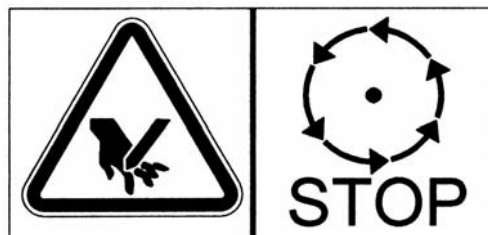

DANGER OF HAND INJURY. SWITCH OFF THE ENGINE



DANGER OF FOREIGN OBJECTS BEING THROWN OUTWARDS.
SAFETY GOGGLES MUST BE WORN

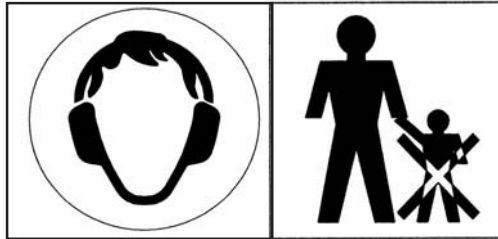

EARMUFFS MUST BE WORN. DO NOT ALLOW CHILDREN NEAR
THE MACHINE WHEN IN OPERATION.

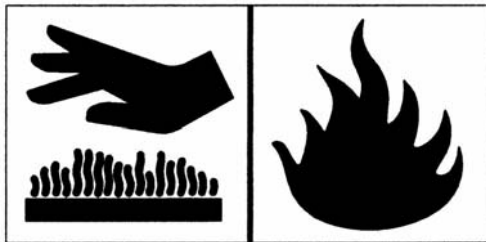

CAUTION: HOT PARTS. DANGER OF BURNS. FIRE HAZARD.

3. TECHNICAL DATA OF THE TURF CUTTER

MOD.	IB300	IB390
ENGINE :	Petrol HONDA GX 200	
ENGINE CAPACITY :	3.7 kW	3.7 kW
CUTTING WIDTH :	30 cm	39 cm
CUTTING HEIGHT :	adjustable up to 35 mm	
SPEED GEARS :	2 forward gears	
TRANSMISSION :	mechanical	
GEARS :	in oil bath	
START :	recoil	
HANDLEBARS :	height-adjustable	
TYRES :	front tyres = GARDEN 3.00-4 rear tyres = GARDEN 4.10/3.50-4	
DIMENSIONS L x W x H (mm) :	780 x 420 x 610 mm	
WEIGHT (kg) :	73	74
ACOUSTIC PRESSURE, measured according to EN 12733:	86,2 dBA	
ACOUSTIC POWER, measured according to EN 12733:	LWA 97 dBA	
MEASUREMENT UNCERTAINTY K	1 dBA	
VIBRATION LEVEL TRANSMITTED TO THE HANDLEBAR (EN 12 733) AW:	1,8 m/s ²	
MEASUREMENT UNCERTAINTY U	0,9 m/s ²	

Environmental conditions

Unless otherwise stated at the time of ordering it is understood that the machine is to work normally in the environmental conditions covered by the following points.

Environmental conditions other than those described may cause mechanical breakage resulting in the creation of dangerous situations for persons.

ALTITUDE

The altitude of the place in which the machine is to be used must not exceed 1500 m above sea level.

TEMPERATURE

Minimum ambient temperature: -5°C

Maximum ambient temperature: +50°C

ATMOSPHERIC CONDITIONS

The electrical equipment will function correctly in atmospheric conditions with a relative humidity up to 50% at a temperature of 40°C and at 90% with a temperature up to 20°C (without condensate).

ATMOSPHERE WITH RISK OF EXPLOSION AND/OR FIRE

The standard machine herein described is not designed to work in explosive atmospheres or in those with risk of fire.

4. LIFTING AND TRANSPORTATION

All material is carefully checked by the manufacturer before shipping. The turf cutter is delivered in a cardboard box with the handlebars and end part of the cutting height adjustment lever disassembled.

Upon receipt of the machine make sure that it has not been damaged during transit and that the packaging has not been tampered or any parts removed. Report any damage or missing parts immediately to the carrier and the manufacturer with photographic documentation.

After assembling the handlebars and the end part of the cutting height adjustment lever as per the instructions given in paragraph 7 of this manual, the machine may be moved on its own wheels.

The manufacturer is not liable for any damage caused by transportation of the machine after its delivery.

WARNING

Extreme care must be taken during handling to prevent overturning. Avoid steep gradients to prevent loss of control. Make sure that there are no persons present within the danger area.

5. MAIN PARTS OF THE MACHINE

The machine consists of the following main parts:

- A - BLADE CLUTCH CONTROL LEVER
- B - ACCELERATOR CONTROL LEVER
- C - FORWARD CLUTCH CONTROL LEVER
- D - CUTTING HEIGHT ADJUSTMENT LEVER
- E - ENGINE
- F - COVER
- G - BLADE
- H - FORWARD -NEUTRAL-REVERSE GEAR SELECTOR LEVER
- I - ON/OFF SWITCH (1/0)

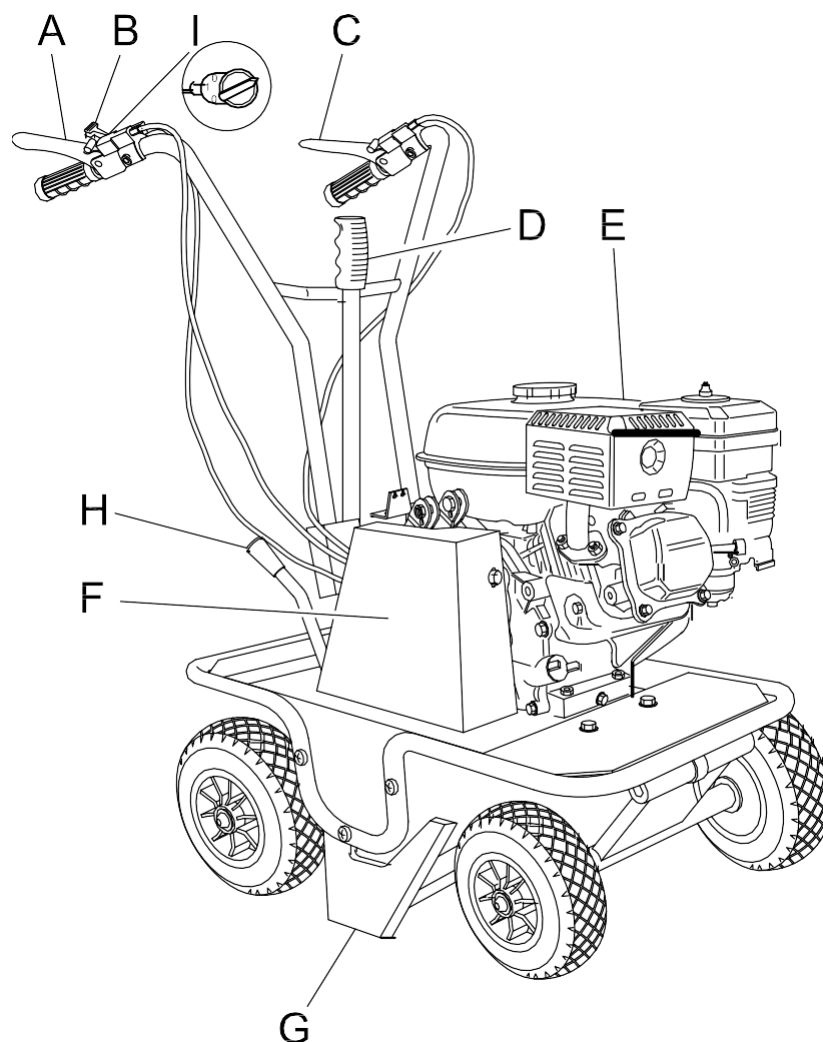

Figure 1

6. CONTROL AND ADJUSTMENTS

A) BLADE CLUTCH CONTROL LEVER

This is used to engage and disengage the blade movement. Lowering the lever engages the clutch and releasing it disengages the clutch.

WARNING

The blade will continue to move if the engine is running and the blade clutch is engaged, regardless of the position of the forward clutch.

B) ACCELERATOR CONTROL LEVER

This is used to adjust the number of engine revolutions according to the operations to be carried out. Hence at switch on the lever will be positioned on the minimum setting whilst during work operations it will be positioned as required by use.

C) FORWARD CLUTCH CONTROL LEVER

This lever only has two positions: engage and disengage. Lowering the lever engages the clutch and releasing it disengages the clutch.

This lever automatically operates the service brake: when released the lever engages the brake, when engaged the lever disengages the brake.

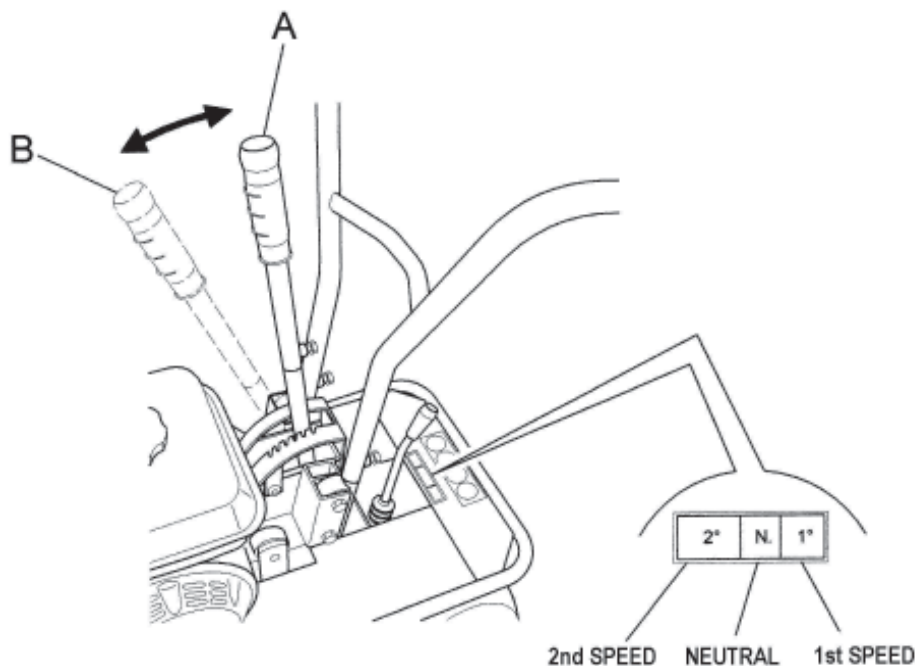

Figure 2

D) CUTTING HEIGHT ADJUSTMENT LEVER

This lever serves to adjust the cutting height according to the type of terrain and the thickness of the turf to be cut. (Fig.2 Ref. A)

F) COVER

The cover (Fig. 1, ref. F) prevents any contact with the moving parts of the machine. Use of the machine without the said cover is strictly prohibited.

I) ON SWITCH

Two-position switch:

(1) for starting the engine

(0) for switching off the engine

L) FORWARD (1st - 2nd)-NEUTRAL GEAR SELECTOR LEVER

This lever selects the gear forward (1st, 2nd), neutral.

WARNING

Select the required gear only after disengaging the forward clutch by releasing the relative lever (Fig. 1, ref. C).

7. ASSEMBLY INSTRUCTIONS FOR THE HANDLEBARS AND END PART OF THE CUTTING HEIGHT ADJUSTMENT LEVER

The turf cutter is delivered with the handlebars and the end part of the cutting height adjustment lever disassembled. Remove the cardboard packaging (to be disposed of in an appropriate manner, in accordance with current regulations in force).

To assemble proceed as follows :

- Lift the handlebar (Fig. 3 Rif. C) and insert it in the supports shown in Fig. 3 rif. E. Select the required cutting height and secure the setting using the screws provided (Fig. 3 ref. D).
- Fit the end part of the cutting height adjustment lever (Fig. 3 Ref. A) into its relative support (Fig. 3 ref. F) and secure using the screw provided (Fig. 3 Ref.B).

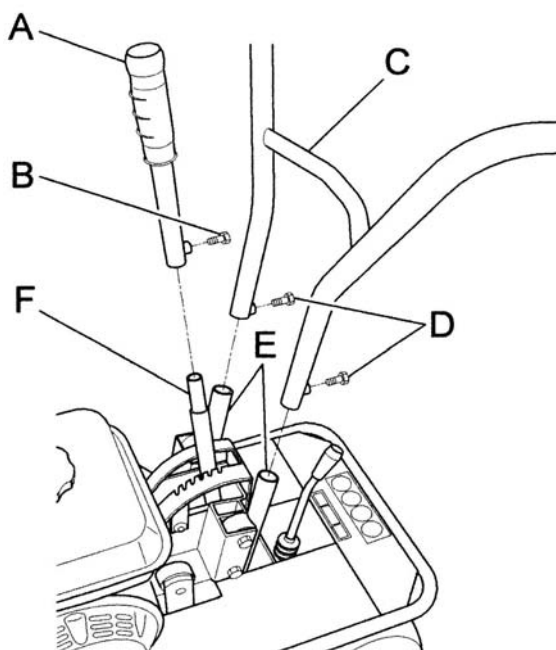

Figure 3

Before switching on ensure that the machine has been fully assembled correctly.

8. SAFETY INFORMATION

Before using the turf cutter it is essential that the operator has understood the warnings, do's and don'ts and precautionary measures given in this manual and in the engine manual: the prevention of injury to the operator, third parties, animals or objects directly depends on observance of these instructions.

A) GENERAL INSTRUCTIONS

- Use of the turf cutter for purposes other than those envisaged is strictly prohibited.
- Climbing aboard and/or riding on the turf cutter is strictly prohibited.
- Tampering with the safety systems and guards is strictly prohibited.
- Modifications to devices/components not envisaged by the manufacturer are strictly prohibited.
- The electrical parts of the engine must be protected at all times.

B) TRAINING

- Read the Operator's Manual and the Engine Manual before using the machine.
- Use of the machine by minors under the age of 16 years or by persons without the necessary psychological and physical capabilities is forbidden.
- Do not use the machine near other persons or within enclosed areas.
- The placing of hands, other parts of the body and clothing in the moving parts of the machine is prohibited.
- It is forbidden to approach the moving parts.
- Before carrying out any inspection or servicing operations make sure that the engine has been switched off and the spark plug wire removed.

C) PREPARATION

- Make sure that the working area around the machine is free of obstacles and has sufficient lighting.
- Before switching on the engine make sure there are no persons, animals or vehicles in the vicinity .
- Before switching on the engine make sure that both engagement levers (forward clutch control lever - Fig. 1, ref. C and blade clutch control lever - Fig. 1, ref. A) are in the disengaged position (released) ; then place the gear lever in neutral (Fig. 2, ref. C)
- Before switching on the machine make sure that the screws, fixing elements and protection devices are in place and that the affixed notices are legible.
- Then: Make sure that the wheel fixing bolts have been tightened fully.
- Secure all blade nuts and fixing bolts to prevent their loss during work operations. Replace any old or worn blades.
- The cover (Fig. 1, ref. F) should not be moved for any reason whatsoever while the machine is in use.
- When switching on the engine check the position of the various control levers (see the section on "Controls and adjustments").
- Supervise the clothing of personnel operating the machine: a long-sleeved jacket with close-fitting cuffs, long, close-fitting trousers, heavy-duty footwear, and a protective cap or helmet should be worn. Avoid wearing loose-tailed clothing, unbuttoned jackets or torn, undone or partially zipped up items to prevent them from being caught up in the moving parts.
- Safety goggles and ear protection devices must be worn. Safety gloves must also be worn during machine operation and maintenance.
- Do not switch on and operate the turf cutter in enclosed areas since the engine gives off carbon monoxide fumes which are colourless, odourless, tasteless and extremely dangerous.

- Take care when handling fuel. Fuel is highly flammable and its vapours explosive :
 - Only use an approved container
 - Take care not to remove fuel caps or top up the tank with the engine running.
 - Allow the engine to cool before proceeding with fuel-filling operations.
 - Do not smoke during this operation.
 - Never fill the machine with fuel in an indoor ambient
 - It is advisable to use a wide funnel to prevent spillage of fuel on the engine and on other surfaces of the turf cutter.
 - If any fuel is spilled do not attempt to switch on the engine; simply move the machine away from the area of spillage before switching on.
 - After filling up with fuel reposition and screw the fuel tank cap right down.
- Do not rest the turf cutter or the fuel container in indoor environments with naked flames

D)WORKING USE

- When working keep everyone at a minimum distance of 10 metres from the machine.
- Keep the engine well ventilated and clog-free (materials and other residue) to prevent damage to the engine and risk of fire. **Clean the cooling fan and fins regularly.** Clean the air filter at the same time as well.
- Drive smoothly, avoiding brusque starts, braking and turns.
- Take care not to touch the silencer when hot.
- When reversing make sure there are no children or animals around. Take care not to get caught up in the moving parts of the machine.
- If a slipping belt causes abnormal noise, smells or overheating, switch off the engine immediately and check the machine to prevent the outbreak of fire and damage to the transmission.
- The blade is extremely dangerous. Take great care during operation. Do not use feet or hands to push the machine down into the turf and do not allow anyone to stand either in front of the machine or in its direction of travel.

WARNING

During operation the lawn and turf are cut into strips. Should the cutter's wheels skid during use it is advisable to adjust the cutting height using the special lever (Fig. 3, ref.A). If this operation does not prevent this occurrence check the state of the terrain. If it is too dry it should be wetted so that the blade encounters a slight resistance, thus making cutting operations easier.

WARNING

When working in a stony or obstacle-riddled area try to remove as many objects as possible before commencing cutting. Then work at a greater cutting height than usual.

WARNING

Stones and other objects may be thrown outwards in direction of the perator or of other persons in the vicinity. Keep at a safe distance from persons, nimals and objects.

- If the cutting mechanism accidentally comes into contact with an object (stump or stone), switch off the engine and carry out the following operations:
 - Inspect the damage
 - Do not attempt to repair it if unskilled to do so
 - Check that no parts have come loose

- Do not use the machine if it does not work properly or is broken: seek authorized service.
- It is strictly prohibited to leave the turf cutter running whilst unsupervised.
- It is strictly prohibited to transport the machine with the engine running. When loading the machine onto a vehicle, the inclination of the ramps must not exceed 15°.

WARNING

EXERCISE CAUTION WITH GRADIENTS. Danger of machine overturning.

- Given its outdoor use, it is advisable not to use the turf cutter when it is raining.
- The area next to the engine exhaust may reach a high temperature.

WARNING

Danger of burns.

- Do not go near water fountains or precipices and do not cross narrow bridges during work operations to prevent the risk of falling.
- Do not work on steep banks
- In the instance of difficulty or emergency stop simply release the forward clutch control and blade movement levers and return the gear lever to neutral position.
- Work on flat ground for the utmost safety.

E) AFTER USE

- Before moving away from the machine, place the gear lever in neutral (Fig. 2, ref. C) and switch off the engine by moving the switch (Fig.1,ref.l) to the 0 position.
- For greater safety shut off the feed cock (Fig. 4).

9. TRANSPORTATION OF THE MACHINE

LOADING AND UNLOADING FROM A VEHICLE

- For transportation it is preferable to use a vehicle with an open bed.
- Choose firm, flat ground.
- Switch off the vehicle's ignition, put into reverse gear, pull on the hand brake and block the tyres with chocks to prevent accidental movement of the vehicle.

WARNING

Raise the blade to maximum height to prevent danger of its catching the ramp edges.

- Do not stand in front of the machine
- Firmly hook the loading ramps onto the vehicle bed.
Use stable load ramps with a non-slip surface strong enough to take the weight of the machine. The inclination of the ramps must not exceed 15°.
Recommended length : at least 3¹/₂ times the vehicle bed's height from the ground.
Recommended width : to be chosen according to the tyre width of the machine
- Proceed with the loading of the machine, manoeuvring it carefully. Set the accelerator lever at minimum (Fig. 1, ref. B) and using the lever as shown in figure 2, ref. C, engage the forward gear for loading, or the reverse gear for unloading.
- During loading/unloading operations on the ramps avoid operating the blade clutch (Fig. 1, ref. A) and the gear lever (Fig. 1, ref. H) because such actions may prove extremely dangerous.
- Line the front wheels up with the centre of the loading ramps.
- Take care when the machine passes from the loading ramps to the vehicle bed, because a shift in balance occurs.

- Once loaded, turn off the engine using the relative switch (Fig. 1, ref. I), make sure that the service brake has automatically come into operation upon release of the forward clutch control lever (fig. 1, ref. C), block the machine wheels using chocks and firmly tie the machine to the vehicle.

10. DESCRIPTION OF THE SAFETY AND GUARD SYSTEMS

WARNING

The safety devices must never be tampered with. It is necessary to understand how they work and safeguard their efficiency and correct operation. In the instance of doubt, problems or malfunction contact your dealer.

FORWARD CONTROL AND BLADE MOVEMENT LEVERS

When released both of these levers instantly disengage the transmission connected to them. In this way they act as safety devices.

In the instance of difficulty or sudden emergency, the quick release of these levers will return them to their standard position (raised).

COVER

The cover (Fig. 1 point F) partially protects the machine from any projected objects and contact with the moving blade. Use of the machine without the said cover is strictly prohibited.

The cover should only be removed when replacing belts with the machine switched off.

11. OPERATIONS TO BE CARRIED OUT BEFORE SWITCHING ON

Position the turf cutter outdoors on sufficiently firm, flat soil. Read the instructions provided by the engine manufacturer in the relative manual and follow them carefully to prevent situations arising which may endanger either persons or the machine.

WARNING

New machines straight from the factory do not have any engine oil.

Then check:

- the state of the blade by inspecting them;
- that all the screws are tightened, particularly those securing the blade;
- that the guards and safety devices are securely tightened.
- Before switching on the turf cutter make sure that there are no persons in the vicinity.
- During operation do not allow persons near the machine, especially children. The operator is responsible for any harm done persons in the working area of the machine.

Oil recommendations

The engine is supplied without oil. Before starting up the engine fill with oil and check the oil level with the engine in a horizontal position. Do not overfill.

Use of a high-grade detergent oil is recommended (refer to the enclosed engine manual).

Fuel recommendations

Use of fresh, clean lead-free petrol is advised.

WARNING

It is advisable to consult the engine manual before switching on the machine.

12. STARTING AND DRIVING THE TURF CUTTER

The machine can be switched on once all the aforementioned preliminary operations have been carried out.

Place the feed cock in the OPEN position (direction shown by the arrow, Fig. 4).

Bring the choke to the CLOSED position for a cold start (direction shown by the arrow, Fig. 4a).

Set the accelerator lever at the minimum position.

Grip the engine pull lead handle (fig. 4b) and pull gently until you feel the “bite”, then pull on the lead sharply to overcome the pressure, prevent kickback and switch on the engine.

Repeat the procedure, if necessary, with the accelerator lever in INTERMEDIATE position.

Once the engine is running, set the accelerator in the MINIMUM position and gently return the choke to the OPEN position (Fig. 4a).

Cleaning of the machine is recommended after use (see the section “Cleaning the machine”).

Figure 4

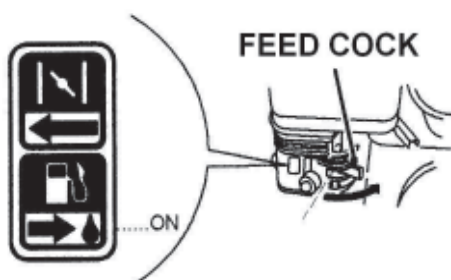

Figure 4a

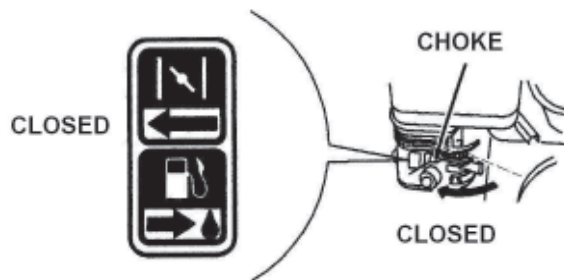
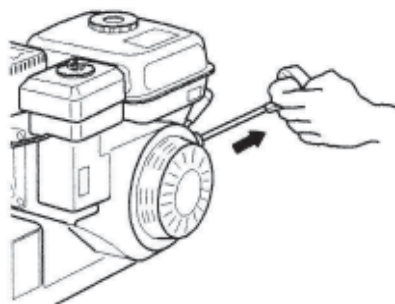

Figure 4b



DRIVING THE MACHINE

WARNING

When using the machine for the first time it is advisable to get the feel of it by executing manoeuvres on flat ground free of foreign objects.

After switching on the engine following the instructions given in the previous paragraph:

1. Move the gear lever (fig. 2, ref. C) to the FORWARD position.

WARNING

If the gear engages with difficulty, partially engage the clutch for an instant before trying to engage the gear again.

2. Engage the blade control level using the relative lever (Fig. 1, ref. A).

WARNING

Choose a cutting height suitable for the type of terrain the machine is to be used on.

3. To move the machine, accelerate and then engage the forward clutch using the relative lever (Fig. 1, ref. C).
4. To select a different gear the forward clutch and the blade clutch must first be disengaged by releasing their levers (Fig. 1, ref. C and Fig. 1, ref. A). Then select the desired FORWARD position (1°- 2°, in fig. 2, ref. C) using the gear lever (Fig. 2, ref. C), then re-engage the forward clutch control lever (Fig. 1, ref. C) to set the machine in motion again.
5. To stop the blade release the relative lever (Fig. 1 ref. A).
6. To stop forward movement of the machine release the relative lever (Fig. 1, ref. C), then switch off the engine by moving the switch to the position (O) (Fig. 1, ref. I).

13. CUTTING TIPS

1. Before commencing cutting operations, read the safety instructions given in the previous sections.
2. At first the setting of a relatively high cutting height is recommended (using the relative lever in figure 2, ref. A), lowering it gradually according to working conditions.
3. Engage the blade clutch (Fig. 1, ref. A) only after having carried out the machine switch-on and gear engagement operations.
4. Before engaging the blade clutch (Fig. 1, ref. A), gradually move the accelerator (Fig. 1, ref. B) until the required speed is reached.

WARNING

Take great care because the blade moves at very high speed.

5. Keeping blade movement engaged in reverse is prohibited.

14. CHECKS

- Adjust the belt and cable control tension after the first few working hours to compensate initial loosening.
- Briefly operate all the machine's components to detect any abnormal noises or overheating.
- During the initial running in period avoid heavy-duty usage to encourage proper settling of the mechanical parts.
- Never neglect maintenance operations after work and carry out all prescribed checks regularly.

A) TYRE PRESSURE

Regularly check the tyre pressure. If both two tyres are not inflated to average pressure the machine will tend to travel sideways during operation.

B) CABLE CONTROL ADJUSTMENT

To adjust the cables place the machine on flat ground, switch off the engine and disconnect the wire from the spark plug.

B1) BLADE CONTROL CABLE

Make sure that there is no play between the upper end of the cable and the adjustment screw. If there is, or if the cable has stretched, restore to ideal position using the relative adjustment screw (Fig. 5, ref. A).

If adjustment using the relative screw proves ineffective, the belts, and hence the engine mounting, must be adjusted. To perform this operation refer to section 14C "BELT REPLACEMENT AND ADJUSTMENT" of this manual.

B2) FORWARD CONTROL CABLE

Make sure that there is no play between the upper end of the cable and the adjustment screw. If there is, or if the cable has stretched, restore to ideal position using the relative adjustment screw (Fig. 5, ref. A).

If adjustment using the relative screw proves ineffective, the belts, and hence the engine mounting, must be adjusted. To perform this operation refer to section 14 C "BELT REPLACEMENT AND ADJUSTMENT" of this manual.

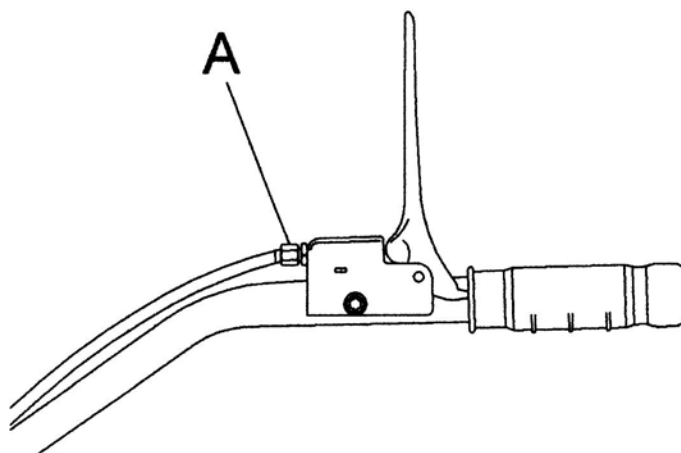

Figure 5

C) BELT REPLACEMENT AND ADJUSTMENT

Switch off the engine and disconnect the spark plug wire before carrying out any maintenance or repair work on the machine.

If a belt is worn or breaks it should be replaced as follows:

- remove the metal guard (fig. 6 ref. A), by unscrewing and taking out the screws shown in figure 6 ref. B and C.

C1)BLADE BELT

Disconnect the connecting rod (Fig. 7 Ref. B) by removing the nut and loosening the screw that secure it to the arm (Fig. 7 Ref. C)

- Once the connecting rod has been disconnected the belt can be slipped off (Fig. 7 Ref. A) by manually turning the relative lower pulley anticlockwise (Fig. 7 Ref. D).
- To fit the new belt follow the procedure in the reverse order.
- Afterwards check that the belt is correctly positioned by using the relative blade control lever. When this lever is lowered and the belt is at maximum tension, the distance between the belt and the relative belt guides (Fig. 7 Ref. E) should be approximately 2 mm.
- Then make sure that the belt works properly by tugging lightly on the self-winding starter cable with the engine switched off and the spark plug wire disconnected. If everything is working properly the pulley will turn on the engine but will not engage the belt.

If the belt engages push the engine back slightly towards the rear of the machine (in the direction of the handlebars) until the belt is in the correct position.

C2)FORWARD CONTROL BELT

Remove the blade control belt following the instructions given in the preceding paragraph.

- Remove the blade (Fig.1 Ref. G) following the instructions provided in the section entitled "Blade removal and replacement".
- Then remove the forward control belt from the lower pulley by turning the belt anticlockwise (Fig. 8 Ref. A e B)
- To fit the new belt follow the procedure in the reverse order.
- Afterwards check that the belt is positioned and working correctly using the relative forward control lever. When this lever is lowered and the belt is at maximum tension, the distance between the belt and the relative belt guides (Fig. 8 Ref. C) should be approximately 2 mm.
- Then make sure that the belt works properly by tugging lightly on the self-winding starter cable with the engine switched off and the spark plug wire disconnected. If everything is working properly the pulley will turn on the engine but will not engage the belt. If the belt engages push the engine back slightly towards the rear of the machine (in the direction of the handlebars) until the belt is in the correct position.

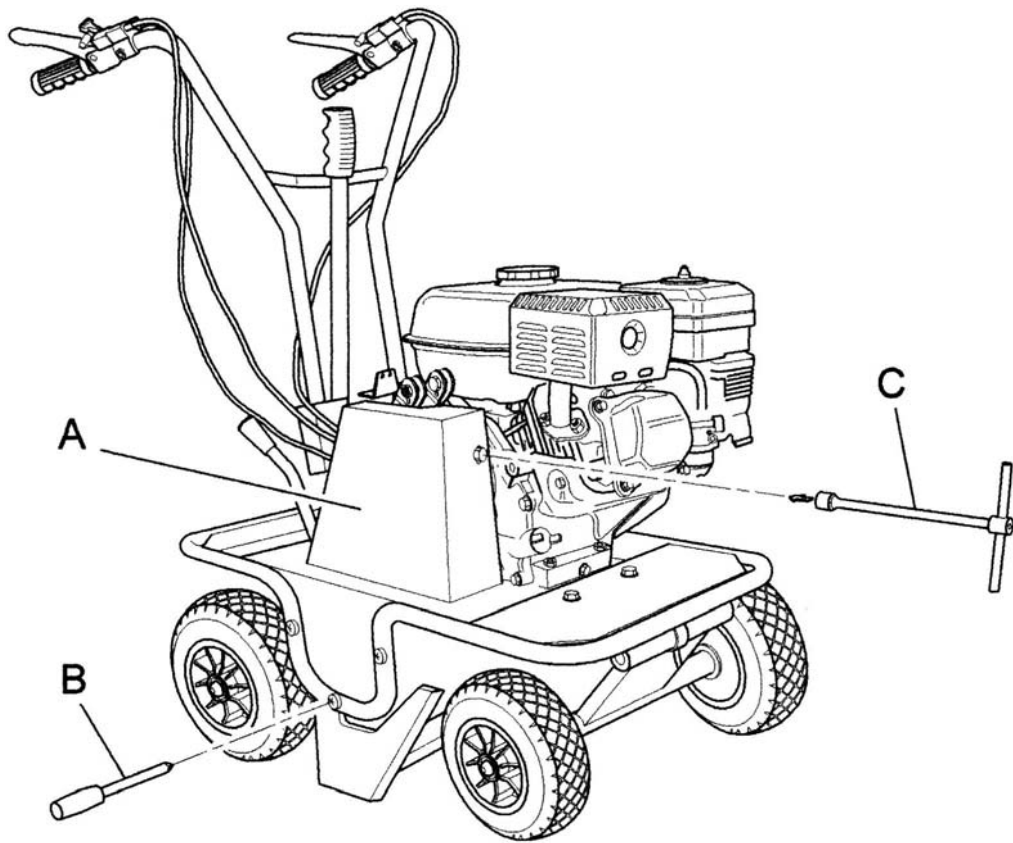

Figure 6

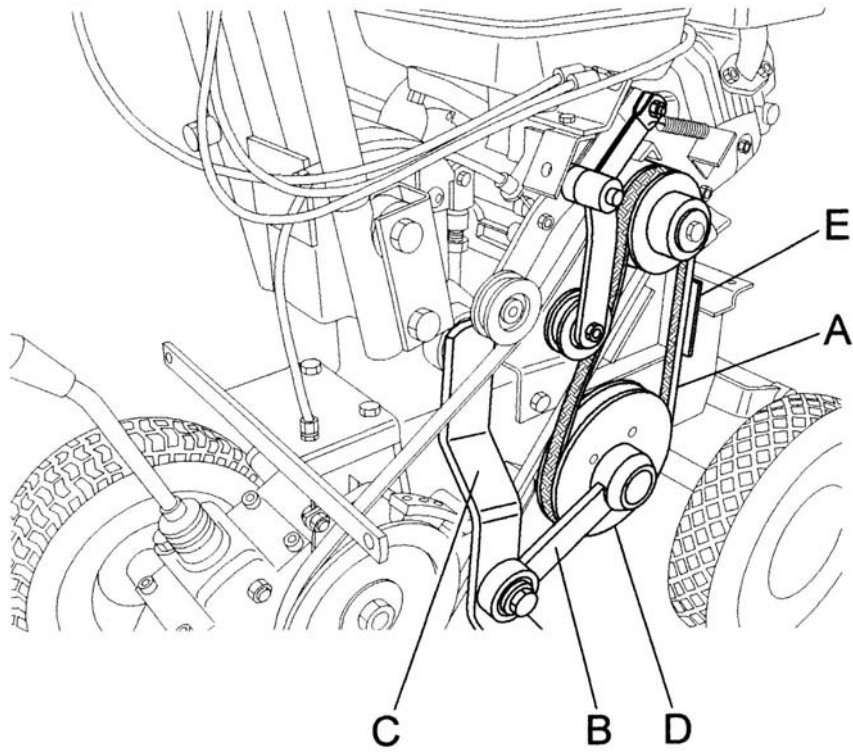

Figure 7

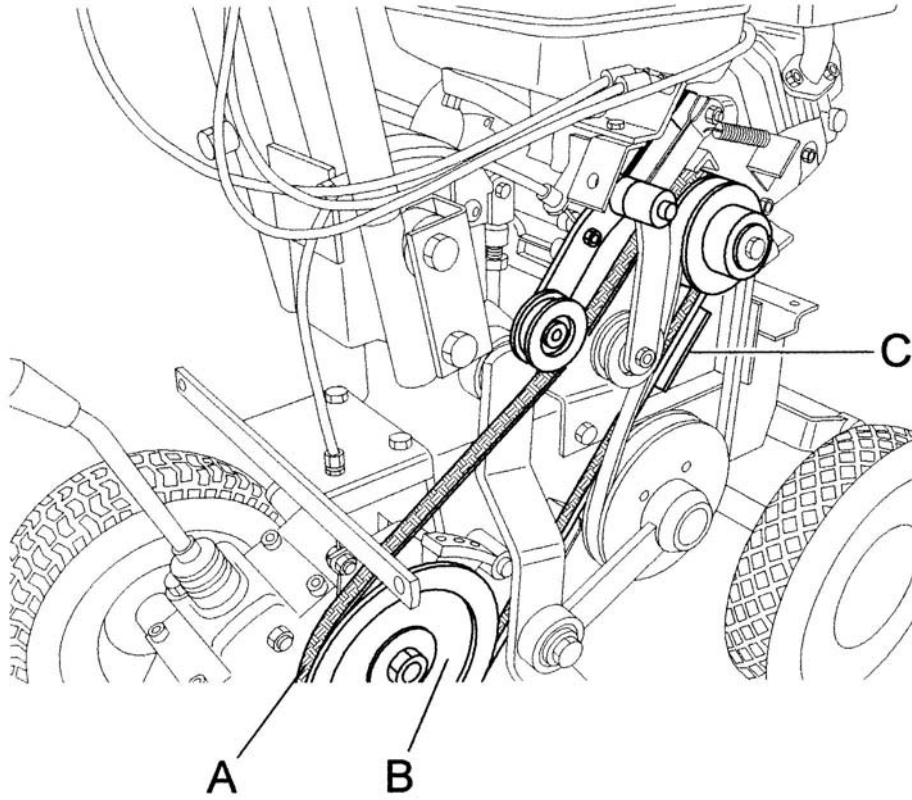

Figure 8

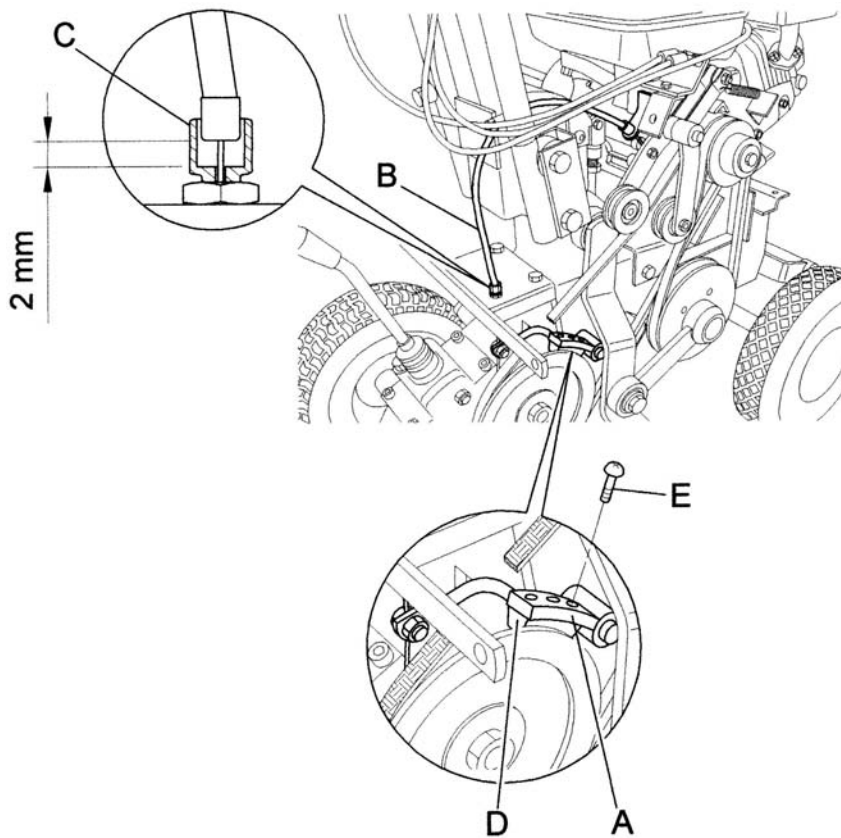

Figure 9

D) SERVICE BRAKE CONTROL LEVER

The service brake (Fig. 9 Ref. A) is connected to the forward control lever (Fig. 1 Ref. C). With the forward control lever released and the brake engaged ensure that there is play of approximately 2 or 3 mm between the adjustment screw and the brake cable (Fig. 9 Ref B and C).

WARNING

If there is no such play restore it immediately since the brake will not stop the machine once the forward control lever is released. Make sure that the front part of the brake in direct contact with the pulley (Fig. 9 Ref. D) is not worn. If so, replace it.

E) CHECKING AND REPLACING THE BLADE

Always check the state of the blade before commencing work. Do not forget to switch the engine off!

- During work operations if the blade (Fig. 10, ref. A) strikes stones or stumps stop straightaway and make sure that it has not become bent or broken. A damaged blade must be replaced.
- If the blade is very worn, cracked or bent, it makes snap and projects objects outwards, risking serious accident.
- Use heavy-duty work gloves to check or replace the blade to avoid risk of injury to hands.
- The blade fixing screws and relative nuts are also subject to wear. Always replace them at the same time as the blade, using bolts and screws of the same strength and type.
- The blade wears more quickly on dry, sandy ground. In these conditions it should be replaced more frequently.

To remove the blade proceed as follows:

1. Switch off the engine and disconnect the spark plug wire
2. Adjust the cutting height to maximum
3. Check the state of the blade.

Check that the blade is not cracked, bent, excessively worn or broken.

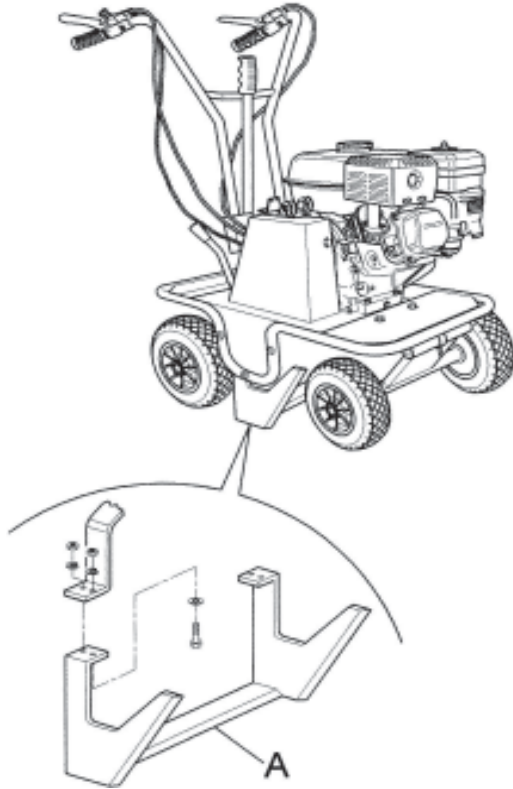

Figure 10

15. MAINTENACE AND STORAGE

- All operations on the machine must be carried out exclusively by authorized personnel.
- Always switch off the engine when checking, adjusting or servicing the machine.
- Allow the machine to cool down before inspection.
- The cover (Fig. 1 ref. F) must always be correctly installed and intact. If it becomes damaged, have it repaired before the machine is used again.
- Make sure that all the guards of rotating and moving parts are in place.
- For greater safety, when replacing the blade replace all the fixing screws and nuts at the same time, as described in section 14, point D.
- Inspect the fuel lines. These should be replaced if damaged or after a maximum of three years, along with the fixing bands. Old lines may leak fuel.
- Check and regularly adjust the forward clutch control, blade clutch control, accelerator.
- Cover the machine with a sheet after the engine and silencer have cooled down.
- It is strictly forbidden to place/leave unattended on the turf cutter any potentially dangerous objects which may put the safety of persons or the machine at risk.
- Keep the machine in a good, clean state; do not leave it outside exposed to inclement weather conditions.
- After use store the machine in a place where children have no access. Always allow the machine to cool down before putting it away.
- After use store the machine in a place where fuel vapours cannot reach a naked flame or sparks.
- In the instance of a long period of non-use, drain the fuel tank completely.

Use of the machine does not require specific lighting.

However, the recommended minimum amount of light (e.g. 200 lux) is enough to be able to read the notices on the machine and to operate it without running risks caused by poor light.

CHECKING AND REPLACING THE TRANSMISSION OIL

Check the transmission oil level using the relative oil level screw (fig. 11 ref. C). If oil leaks out upon removal of this screw then there is enough of it in the transmission. If not, remove the filling cap shown in fig. 11 ref. A, then top up with SAE 90.

The oil should be replaced after the first 20 hours of use and after this every 100 working hours.

Remove the drainage cap shown in fig. 11 (ref. B) and allow all the oil to run out. After refitting the drainage cap, fill the transmission from the filling cap with SAE 90 transmission oil.

Refit the lid securely to prevent any leakage of oil.



Abbildung 11

16. CLEANING THE MACHINE

Proceed in the following order:

- Switch off the engine and disconnect the spark plug wire;
- Clean the engine and the outside of the machine with a cloth soaked in a little oil.
- Clean all parts of the machine, particularly the starting unit, air filter, exhaust and carburetor. It is advisable to follow the instructions given in the engine manual.
- Clean the inside of the belt guard (fig. 1, ref. F) with a blast of compressed air.
- To clean the blade (fig. 1 ref. G), wash with a jet of water straight after use while still damp. When washing carefully cover and protect the electrical parts of the engine, the carburetor, the air filter and the exhaust from the water to prevent engine problems.
- To clean the blade area a tool should be used (stick of wood).

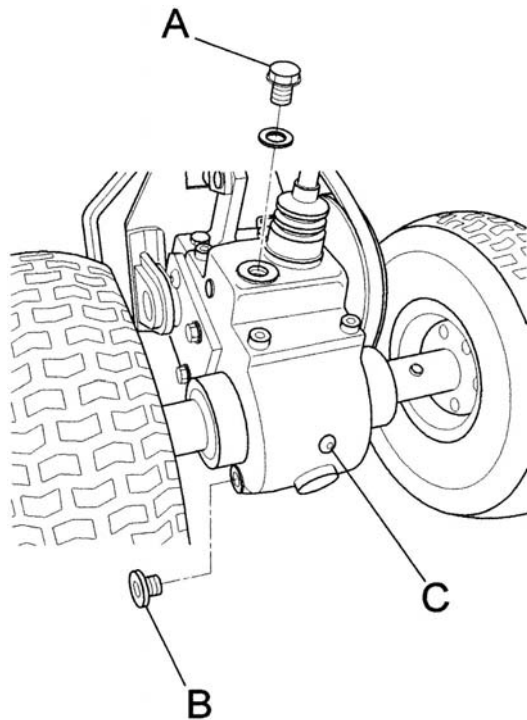
17. SEASONAL LONG-TERM STORAGE PERIODS

To store the turf cutter for prolonged periods of non-use, proceed as follows:

- Park the machine on flat, firm, clean ground.
- Oil deposits on the ground where the machine is positioned may cause irreparable damage to the tyres.
- Disconnect the spark plug wire;
- Clean the machine carefully as described in section 16 (Cleaning the machine)
- Make sure that all screws and nuts are fully tightened.
- Retouch with paint any parts which have become exposed during use.
- Store the machine in a clean, dry place.
- Empty the fuel tank, following the instructions given in the engine manual;
- Regularly check the tyre pressure, and adjust if necessary.
- Lubricate all moving parts and have any necessary repairs to the machine carried out.

18. DECOMMISSIONING AND SCRAPPING

After the working life of the turf cutter the user must have it dismantled and its components removed as per EEC directives or in accordance with current legislation in force in his country, taking particular care over the dismantling of the following materials of environmental impact:

- plastic parts
- rubber parts
- coated electric wiring
- petrol engine
- metal parts
- toxic substances

19. TECHNICAL ASSISTANCE

Routine maintenance must be carried out as per the instructions given in this Manual. For any instances not covered herein and for technical assistance in general contact your dealer referring to the data given on the identification plate affixed to the machine.

The right reference will ensure swift, precise answers.

For swift delivery of spare parts always quote the following information on the order:

- Machine model and serial number
- Part description and quantity required

For assistance concerning the engine it is advisable to contact the service centre authorized by the engine manufacturer (see engine manual supplied).

20. WARRANTY

The turf cutter has a 12-month warranty which starts from the day of purchase, (or up to 50 hours' service, if for individual use) or 6 months (or up to 50 hours' service, if for commercial use) excluding the engine, for which the warranty supplied by its manufacturer applies.

The manufacturer will replace free of charge any parts it acknowledges to be faulty. Labour and transportation costs are to be paid by the customer.

For any problems or repair enquiries please contact your dealer. Warranty applications must be forwarded to the manufacturer via the dealer.

Any damage during transit must be reported to the dealer immediately.

As regards any materials not manufactured by us, particularly the engine, the regulations of the respective manufacturers apply. So, any applications for repairs must be forwarded to the specific service centres within those specific areas.

If maintenance work carried out on the machine does not conform to the instructions provided, involving the use of non-original spare parts or without the written authorization of the manufacturer, thus jeopardizing the integrity of the machine or changing its characteristics, the manufacturer will not be liable for the safety of persons or for the faulty operation of the machine.

All unauthorized modifications to the machine invalidate the warranty agreement.

21. CE MARKING

The plate bearing the CE mark (Fig. 12, ref.A) gives the main characteristics and information for the identification of the turf cutter.

- Manufacturer's details
- Machine model
- Serial number
- Year of construction
- Capacity in kW
- Weight in kg

The above information must not be altered or modified in any way.

It is up to the user to keep the plate clean, legible and in good condition.

The position of the CE plate on the machine is shown in the figure below:

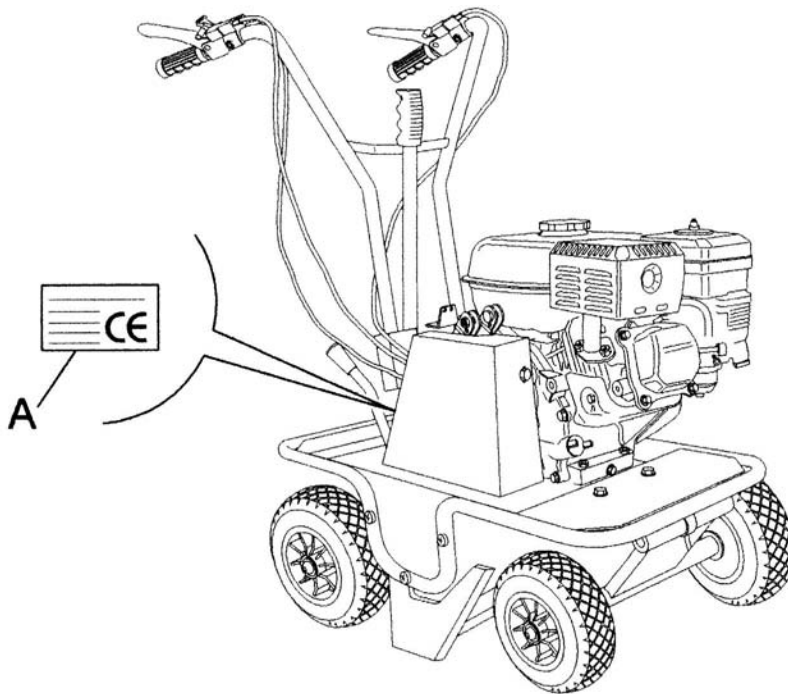

Figure 12

22. TROUBLESHOOTING

The following table illustrates some problems which may arise during operation.

FAULT	CAUSE	MEASURES TO BE TAKEN
Belt slips	<ol style="list-style-type: none"> 1. Belt tension inadequate 2. Too great a working depth 3. Belt worn 	<ol style="list-style-type: none"> 1. Adjust the belt tension 2. Reduce the working depth 3. Replace belt
Machine vibrates excessively	<ol style="list-style-type: none"> 1. Belt damaged 2. Blade bent or broken 	<ol style="list-style-type: none"> 1. Replace belt 2. Replace blade
Engine overloads during work operations	<ol style="list-style-type: none"> 1. Engine speed too low. 2. Blade worn 3. Forward speed too high 4. Too great a working depth 	<ol style="list-style-type: none"> 1. Accelerate to maximum 2. Replace blade 3. Decrease the forward speed 4. Reduce the working depth

ENGINE

FAULT	CAUSE	MEASURES TO BE TAKEN
Engine sluggish at switch on	<ol style="list-style-type: none"> 1. accelerator not in start-up position 2. Choke not closed 3. Petrol does not arrive 4. Air bubbles or water inside the petrol lines 5. Thick oil prevents rotation 6. Winding or start mechanism faulty 7. Spark plug in poor condition 	<ol style="list-style-type: none"> 1. move the accelerator to the intermediate position 2. Close the choke when cold. 3. Check the fuel tank and remove any water or sediment.. Make sure that the feed cock is open. 4. Check the lines and bands. Repair or replace if damaged 5. Use oil with a viscosity suited to the temperature 6. Replace winding or start mechanism 7. Clean or replace spark plug. Adjust the distance between the electrodes.
Poor power	<ol style="list-style-type: none"> 1. No fuel 2. Air filter blocked 3. Elastic bands worn 	<ol style="list-style-type: none"> 1. refill tank with petrol 2. clean air filter 3. replace elastic bands
Engine stalls	<ol style="list-style-type: none"> 1. no fuel 2. feed cock shut off 	<ol style="list-style-type: none"> 1. refill tank with petrol 2. open feed cock
Exhaust fumes dark	<ol style="list-style-type: none"> 1. low grade fuel 2. too much engine oil 	<ol style="list-style-type: none"> 1. replace with high grade fuel 2. restore engine oil to correct level
Engine emits black smoke and power is poor	<ol style="list-style-type: none"> 1. air filter blocked 2. choke not fully opened 	<ol style="list-style-type: none"> 1. clean air filter 2. open the choke completely
Exhaust fumes bluish	<ol style="list-style-type: none"> 1. too much engine oil 2. elastic bands worn 	<ol style="list-style-type: none"> 1. restore engine oil to correct level 2. replace elastic bands
Silencer becomes red through overheating	<ol style="list-style-type: none"> 1. air filter blocked 2. Inside of self-winding starter blocked with grass cuttings 	<ol style="list-style-type: none"> 1. clean air filter 2. clean self-winding starter housing

For any problems not easily resolved or in case of doubt you are advised to contact your dealer.

CE DECLARATION OF CONFORMITY

The undersigned manufacturer and depositary of the documentation:

**IBEA SRL
VIA MILANO, 15/17 21049
TRADATE (VA) ITALIA**

Hereby declares under its own responsibility that the new machine

<i>type:</i>	(TURF CUTTER)
<i>model:</i>	IB300 – IB390
<i>year of manufacture:</i>	2016
<i>engine power:</i>	3.7kW

describes as follows:

Machine designed to cut 30 cm – 39 cm wide strips of turf.

Conforms to the Essential Health and Safety Requisites of Directive 2006/42/CE, and subsequent amendments.

*Applicable standard: EN ISO 12733:2019 – EN ISO 13857:2019 – EN ISO 13849-1:2015
– EN ISO 20643:2008/A1:2012 – EN ISO 12100:2010 – ISO 11684:1995*

Date
Tradate, 15/07/2016

(Legal Representative)
Firma: Ing. Alberto Griffini





IBEA s.r.l. Via Milano, 15/17 - 21049 Tradate (VA)
Tel. 0331-853611 Fax 0331-853676 email: ibea@ibea.it
www.ibea.it